



SAFETY SYSTEM FOR LIQUEFIED PETROLEUM GAS (LPG) WITH MICROCONTROLLER BASED FUZZY DECISION TREE ALGORITHM

Yuda Irawan¹⁾, Uci Rahmalisa²⁾, Refni Wahyuni³⁾, Hendry Fonda⁴⁾
^{1,2,3,4} Department of Information System, STMIK Hang Tuah Pekanbaru, Pekanbaru,
Indonesia
Email: yudairawan89@gmail.com¹, ucirahmalisa89@gmail.com²,
refniabid@gmail.com³, fondaanda@gmail.com⁴

Abstract

The cause of the leak was caused by a hose that was no longer suitable for use in order to cause gas leakage that could have an effect on the LPG gas cylinder explosion. By making an alarm-and SMS-based LPG gas protection device with a MQ-6 sensor, users can see the leak in LPG gas. When this tool operates when a gas leak occurs, the MQ-6 has a leak in the LPG gas hose, so the alarm will sound. When active, the voice sends a command to Arduino to close the LPG gas valve. Then the alarm sends a command to the user via SMS to inform you that "gas leak has occurred" The implementation of this system is helpful so that users can easily see the gas leak so that they can take measures to combust on the gas stove. In this case, the desision tree algorithm will be used in which the internal node tester checks the attribute, each branch of the argument, and the study node class or class distribution leaf. After research, the results obtained are to generate a precision value of 90 per cent, a precision value of 100 per cent and an AUC value of 0.5 with a very good classification value (very good classification) on the PIR sensor and MQ-6. On the basis of these findings, it can be denied that the use of the yahoo sesision tree can be used in an acceptable and reliable manner.

Keywords: Liquefied Petroleum Gas, Microcontroller, PIR Sensor, MQ-6 Sensor, Desision Tree Algorithm.

INTRODUCTION

Gas stoves are very practical to use by many mothers. Gas stoves are used by mothers at home for cooking because they are very practical to use. Even though they don't pay attention to pay attention when cooking while doing other work, the result is that if you have concentrated on other work, you forget about the cooking on the stove. And mothers are worried about using the gas stove because it is more likely to explode. Based on data from the questionnaire taking for 15 LPG gas users

in Pekanbaru from September, there have been many cases of gas leaks and complaints about exploding gas. Basically, the potential for fire to occur will not occur if you know how to use a stove that is good and safe [1]–[4]. The cause of the leak was triggered by a hose that was not suitable for use and a hose that had been bitten by an animal, causing a fire as well as how to understand a gas stove and how to avoid burning food and prevent gas leaks that could have an impact on a gas explosion [5]–[7].





Automatic gas stove guards help users cook in the kitchen with a sense of security [8]–[11]. This tool will help gas stove users when not in the kitchen [12]–[14]. The way this tool works starts from the servo which will automatically open the knob as gas flow to the stove, then the pear sensor will detect movement in the kitchen, and when there is movement in the kitchen the SMS notification does not come in, and when there is no movement in the kitchen, the SMS notification will enter[15], [16].

Then the gas leak is known when the user wants to use the stove, when the gas leaks, the MQ-6 detects that there is a leak in the LPG gas hose, the alarm will sound [1]–[3], [7], [15], [17]–[20] When the sound is on, the sound will send a command to Arduino to close the LPG gas valve. Then the buzzer alarm will send an order to the user via SMS to notify you that "a gas leak has occurred" and the user can quickly find out the danger that will occur and can take steps to avoid an explosion on the gas stove.

METHODS

The method is a stage or steps systematically used in implementing and completing the solutions offered in the manufacture of an LPG gas leak safety system [26].

The method of implementation consists of the following stages:

1. Requirements Analysis and Definition
Here the researcher collects the complete data then performs an

analysis and defines the needs to be used in the form of the MQ-6 sensor as an LPG leak detector connected to the Arduino microcontroller. The system to be made will be applied to a gas stove[27]–[29].

2. System Design

At this System Design stage, the researcher describes the design of the system to be built in accordance with the data analysis carried out, namely when there is a leak in the hose or gas cylinder, the device can automatically detect a leak with an alarm warning [21], [30]–[32] and an SMS will be sent to the user.

3. Implementation

In this implementation stage, the programs in the previous stages were translated into codes using a programming language. In this system the programming language used is C++.

4. Integration and System Testing

In the Integration and System Testing stage, the integration of modules that have been created and tested is carried out to find out whether the system that has been built is in accordance with the design and whether there are still errors or not.

5. Operation and Maintenance

In this Operation and Maintenance stage, a system that has been run must be maintained. Maintenance also includes fixing errors that could not be found in the previous stage.





RESULT

Hardware Design

In designing this tool starting from the servo which will automatically open the knock as a gas flow to the stove then entered. And it will detect a leak in LPG gas, then the Buzzer Alarm will turn on. When the Buzzer is on, the Buzzer will send an order to Arduino to close the LPG gas valve. Then the Buzzer Alarm will send an order to the user via SMS to give notification that "Gas leak has occurred" and the user can quickly find out the danger that will occur and can take steps to avoid an explosion on the gas stove. In this tool, the components used are ArduinoUno, PIR Sensor, MQ-6 Sensor, Servo Motor, Sim800l, Buzzer and Mobile. Mobile is a device used on stoves and can receive notifications that "a gas leak has occurred".

In this tool, the components used are ArduinoUno, PIR Sensor, MQ-6 Sensor, Servo Motor, Sim800l, Buzzer and Handphone. Mobile is a device used on stoves and can receive notifications that a gas leak has occurred.

1. Arduino Uno circuit

ATmega328 based microcontroller board (datasheet) [18], [30], [33], [34]. It has 14 input pins from digital output where 6 of these input pins can be used as PWM output and 6 analog input pins, 16 MHz crystal oscillator, USB connection, power jack, ICSP header, and reset button [35]–[38]. To support the microcontroller so that it can be used, it is enough just to connect the Arduino Uno Board to the computer using a USB cable or power

with an AC-to-DC adapter or battery to run it. Can be seen in Figure 1 Arduino circuit.

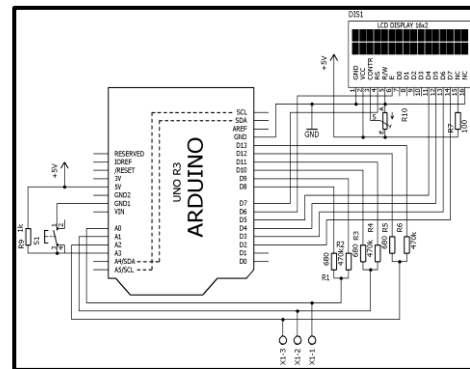

Figure 1. Arduino Uno circuit

2. MQ-6 sensor circuit

The MQ-6 sensor circuit is a component that can be used to convert a certain quantity into an analog unit so that it can be read by an electronic circuit. The MQ-6 sensor can detect / measure something, which is used to convert heat, light and chemicals into voltage and electric current. MQ-6 is a gas sensor used to detect LPG gas.

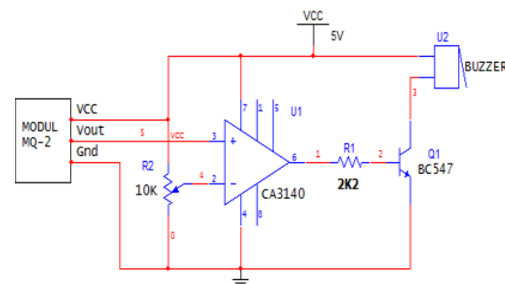

Figure 2. MQ-6 Sensor Circuit

3. Pear Sensor Circuit (Passive Infra Red)





The PIR sensor is a sensor that is used to detect infrared rays from an object [32]. The PIR sensor is passive, meaning that this sensor does not emit infrared rays but only receives infrared radiation from outside[39]. The function of a motion detector that works by detecting a difference / change in temperature now and before becomes electricity. The PIR sensor circuit can be seen in Figure 3.

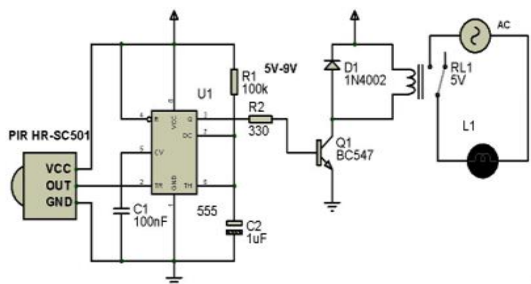

Figure 3. PIR Sensor Circuit

Furthermore, there is a working principle. When a movement occurs at a distance of approximately 5m in front of the PIR sensor, the movement is converted into an electric voltage which then triggers pin 2 of IC NE555. The output pin 3 of IC NE555 activates the relay driver which causes the relay to be in Normally Close mode so that AC power flows to the lamp so that the light turns on. The length of the lamp life is regulated by the R2 and C1 components which are assembled monostable with the NE 555 IC. There are several components that have been structured together including:

- a. PIR HR-SC501 1 piece
- b. Mylar 100nF 1 piece
- c. IC NE555 1 piece
- d. ELCO 1uF 1 piece

- e. Resistors 330, 100k @ 1 piece
- f. 1 piece BC547 transistor
- g. 1 piece 5V relay
- h. 1n4002 diode 1 piece

4. Arduino Uno microcontroller circuit with MQ-6 sensor, Servo Motor, GSM, Pir sensor.

Serves as a connecting medium between the Arduino Uno microcontroller with motion sensors and connecting sensors to detect GAS leaks.

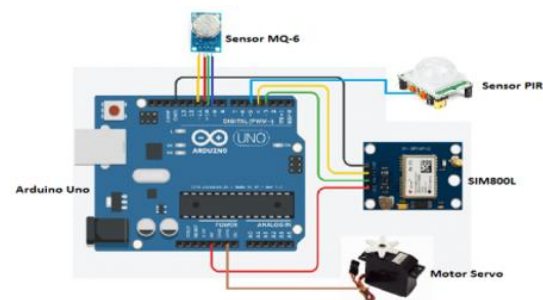

Figure 4. Series of Tools

Furthermore, there are several parts of other hardware devices that are in the microcontroller place. Figure 4 shows the results of implementing the circuit that has been assembled to detect gas leaks. The final results of the entire research series are placed on a circuit board near the gas stove. There are several components that have been assembled in a structured manner including:

1. Arduino Uno (1 piece)
2. SIM800L (1 piece)
3. Servo Motor (1 piece)
4. MQ-6 sensor (1 piece)





5. PIR sensors (3 pieces)

Hardware Implementation

Implementation is one of the stages in system development, where this stage is the stage of putting the implementation of a security system for LPG gas with a microcontroller-based MQ-6 sensor using alarms and SMS, to be operated and can be seen as an effort to realize the system that has been designed. The final result of the design that has been made and designed so as to produce a design tool as shown in Figure 4.1 below where the servo motor that has been designed is then installed on the knock gas where the servo motor will be connected to Arduino using a cable in order to regulate the rotation of the knock gas.

The hardware devices are used as follows:

1. Gas stove
2. PIR sensor
3. MQ-6 sensor
4. Servo Motor
5. SIM800L

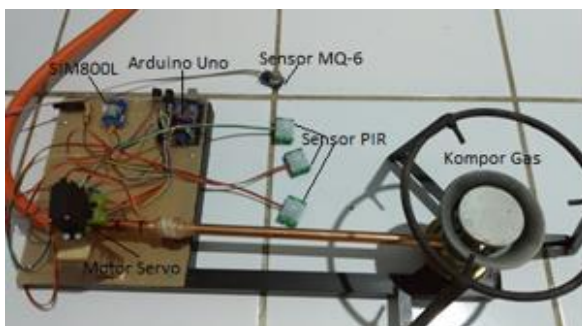

Figure 5. Implementation of Hardware Design

Furthermore, there are several parts of other hardware devices that are in the microcontroller place. In Figure 5, shows a schematic image of the results of the component design that has been assembled and in Figure 4.3 shows the results of the implementation of the circuit that has been assembled to turn off the stove automatically and detect gas leaks. The final results of the entire research series are placed on a circuit board near the gas stove. There are several components that have been assembled in a structured manner including:

1. Arduino Uno (1 piece)
2. SIM800L (1 piece)
3. Servo Motor (1 piece)
4. MQ-6 sensor (1 piece)
5. PIR sensors (3 pieces)

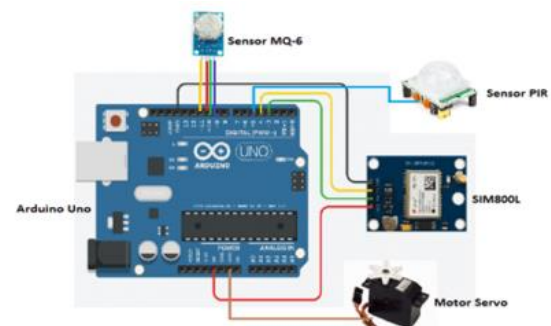

Figure 6. Schematic Circuit Tool

The functions of some of the components above will be explained as follows:

1. Arduino Uno [21], [40] functions as the core of a system process that aims to control and control data that comes from user input or that comes out to carry out functions on the PIR sensor,





- MQ-6 sensor and servo motor.
2. SIM800L functions as a connecting device from Arduino Uno to Cellular Telephones [41]. In order to communicate with Arduino Uno with Cellular Telephones, electricity is needed to capture the signal on the SIM800L. Once connected, a packet credit is also required to be able to send messages and notifications to users. If there is no SIM800L then it cannot send messages and vice versa.
 3. Servo motor functions as a controller or driving device on the knock gas. This servo motor will rotate if there is a gas leak. Then the servo will rotate automatically.

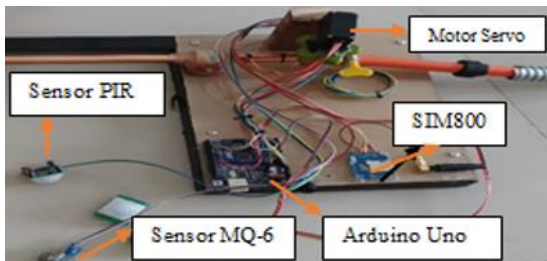

Figure 7. Implementation of the Circuit Tool

Test Results

The results of this test have been carried out on the implementation results on hardware devices and the display results on SMS. Then it will be tested on each component of the hardware device. In the testing process, it aims to make conclusions and analyzes on hardware devices, to be able to find out whether the hardware can receive and send notifications that a leak has occurred correctly and is running well. There are

two tests in this study, namely, testing the functionality of the message input, and testing the quality based on the results of the readings from the PIR sensor and the MQ-6 sensor.

1. Send leak notification messages

Functionality testing is carried out in sending gas leak notification messages. When the user wants to turn on the stove, the sensor reads the gas leak and sends a notification message to the user. The following is a test carried out based on a test scenario sending a gas leak notification message for 2 attempts.

Table 1. Sending notification messages for LPG gas leaks

Trial To-	Scenario Test	Results Obtained	Success
1	Send a Gas Leak SMS notification (Trial 1)	Can Receive the results of the SMS input there is a gas leak. But failed to input more than one number.	Succeeded / In one number input
2	Sending Gas leak SMS notification (Experiment 2)	After making improvements in inputting more than one number successfully	Succeeded / in input of more than one number

Based on Table 1, the test carried out when a gas leak occurs is carried out with three experiments until the test is successful, in the first experiment the SMS notification can be inputted with only one number, in the second experiment the repair process can be input with more than one number, and the third





test input is more than one number done successfully.

2. Quality Testing

a. PIR sensor distance reading suitability.

Table 2. Distance readings on the PIR sensor

Trial To -	PIR Sensor Reading Distance	Information
1	10 Cm	Detected
2	20 Cm	Detected
3	30 Cm	Detected
4	40 Cm	Detected
5	50 Cm	Detected
6	1m	Not detected
7	2 m	Not detected
8	3 m	Not detected
9	4 m	Not detected
10	5 m	Not detected

Explanation of the PIR sensor distance reading test table, in the test table there are different levels of sensitivity on the PIR sensor due to environmental conditions. At a distance of 10-50 cm the reading level of the PIR sensor is very sensitive in detecting someone's presence. At a sensor distance of 1-5 meters, the reading level of the PIR sensor is insensitive in detecting someone's presence because the wavelength generated by the PIR sensor is unable to detect humans.

b. The suitability of the MQ-6 sensor readings in detecting leaks.

Table 3. Display values on the MQ-6 sensor

Trial To -	MQ-6 Sensor Readout	Information
1	608 ppm	Buzzer Doesn't Sound, Valve Is Open

2	9052 ppm	Buzzer Doesn't Sound, Valve Is Open
3	3376 ppm	Buzzer Doesn't Sound, Valve Is Open
4	5166 ppm	Buzzer Doesn't Sound, Valve Is Open
5	856 ppm	Buzzer Doesn't Sound, Valve Is Open
6	30663 ppm	Buzzer Beeps, Valve Closed
7	16729 ppm	Buzzer Beeps, Valve Closed
8	30214 ppm	Buzzer Beeps, Valve Closed
9	16729 ppm	Buzzer Beeps, Valve Closed
10	14991 ppm	Buzzer Beeps, Valve Closed

Explanation of the MQ-6 sensor reading test table, in the table of tests performed on the MQ-6 sensor. At the resulting value if it is below 10 thousand, the buzzer will not sound and the valve will remain open, and at the value on the MQ sensor above 10 thousand or above the normal limit, the buzzer will sound and the valve will be closed.

3. Experimental Results and Method Testing Decision Tree

Here is an illustration of the testing of the Fuzzy Decision Tree algorithm using Rapid Miner Table 2 and Table 3:



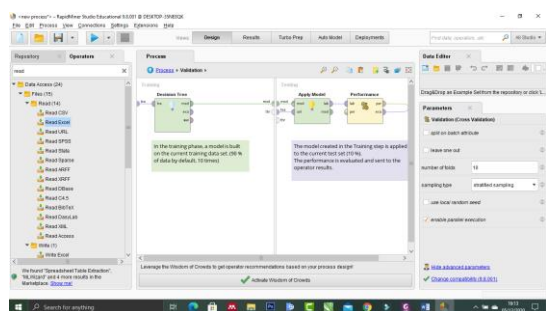

Figure 8. Testing of the Decision Tree Algorithm in Table 2

From the results of Table 2, it can be shown that the best results from the accuracy of the PIR sensor indicate 90 percent of what was previously calculated. Whereas Table 3 indicates the best results for the 90 percent accuracy of the MQ-6 sensor. This can be seen in Figure 9 and Figure 10 below.

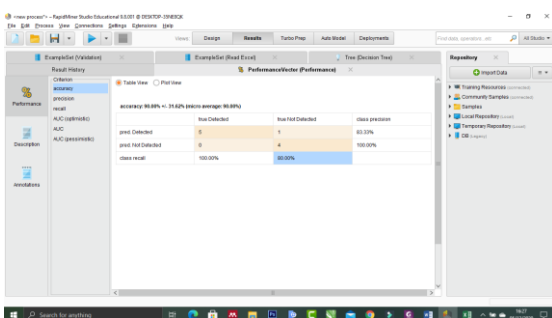

Figure 9. Accuracy PIRSensor in Table 2

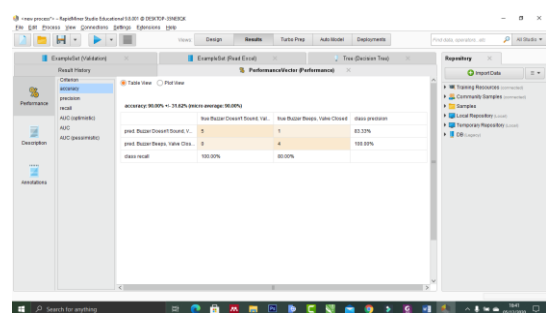

Figure 10. Accuracy PIRSensor in Table 3

Figure 11 and Figure 12 below display the results of the decision tree algorithm tested on Rapid Miner, which shows the results where the PIR sensor > 5.5 does not work well to detect. Unlike the MQ-6 sensor, which shows very good performance, where >5.5 can function properly.

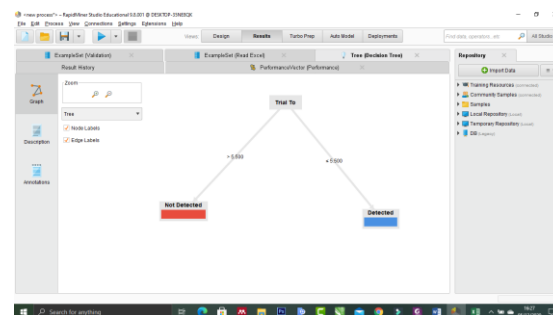

Figure 11. PIR TrialTo Sensor Decision Tree in Table 2

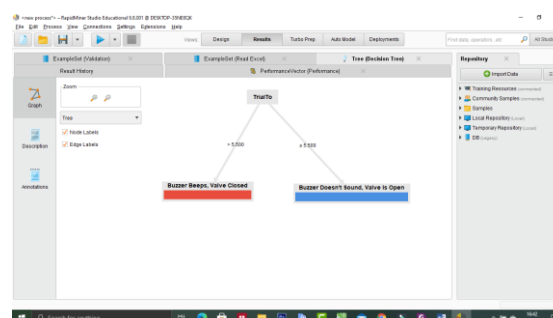

Figure 12. PIR TrialTo Sensor Decision Tree in Table 3

CONCLUSION

The conclusion contains a brief statement based on the findings and results of the thesis that has been done. After testing the hardware device, the following conclusions were drawn: This tool can detect leaks in LPG gas. Can send notifications to users when LPG gas leaks





occur. By using a gas leak detector system, users can take quick action to avoid an explosion on the gas stove. This LPG gas leak detector control system can help people who use LPG gas, especially housewives, and can also help to avoid fires due to LPG gas leaks.

ACKNOWLEDGEMENT

The author would like to thank the STMIK Hang Tuah Pekanbaru for being willing to provide support in conducting this research.

REFERENCE

- [1] J. B. A. Gomes, J. J. P. C. Rodrigues, J. Al-Muhtadi, N. Arunkumar, R. A. L. Rabelo, and V. Furtado, **An IoT-Based Smart Solution for Preventing Domestic CO and LPG Gas Accidents**, in *2018 IEEE 10th Latin-American Conference on Communications (LATINCOM)*, 2018, no. 1, pp. 1–6.
- [2] M. JUALAYBA, K. REGIO, H. QUIOZON, and A. DESTREZA, **“Hazardous Gas Detection and Notification System**, in *2018 IEEE 10th International Conference on Humanoid, Nanotechnology, Information Technology, Communication and Control, Environment and Management (HNICEM)*, 2018, pp. 1–4.
- [3] A. Setiawan, S. J. Sahat, L. B. Subekti, Y. Bandung, and K. Mutijarsa, **Design and Implementation of IoT Sensor System for Home Power Manager and Environment Condition Monitor**, in *2018 International Symposium on Electronics and Smart Devices (ISESD)*, 2018, pp. 1–6.
- [4] M. Santiputri and M. Tio, **IoT-based Gas Leak Detection Device**, in *2018 International Conference on Applied Engineering (ICAE)*, 2018, pp. 1–4.
- [5] A. H. Abdullah *et al.*, **Development of ESP32-based Wi-Fi Electronic Nose System for Monitoring LPG Leakage at Gas Cylinder Refurbish Plant**, in *2018 International Conference on Computational Approach in Smart Systems Design and Applications (ICASSDA)*, 2018, pp. 1–5.
- [6] R. Hosur, A. Rati, P. Dalawai, R. Gornal, and R. Patil, **A Survey on Automatic Detection of LPG Gas Leakage**, in *2018 International Conference on Smart Systems and Inventive Technology (ICSSIT)*, 2018, no. Icssit, pp. 266–269.
- [7] A. Macker, A. K. Shukla, S. Dey, and J. Agarwal, **ARDUINO Based LPG Gas Monitoring Automatic Cylinder Booking with Alert System**, in *2018 2nd International Conference on Trends in Electronics and Informatics (ICOEI)*, 2018, no. Icoei, pp. 1209–1212.
- [8] G. Berruti *et al.*, **Radiation tolerant humidity sensors based on nano-scale TiO coated LPGs for high-energy physics applications**, in *2014 Third Mediterranean Photonics Conference*, 2014, pp. 1–3.
- [9] M. Sahani, A. Nayak, R. Agrawal, and D. Sahu, **A GSM, WSN and embedded web server architecture for Internet based kitchen monitoring system**, in *2015 International Conference on Circuits, Power and Computing Technologies [ICCPCT-2015]*, 2015, pp. 1–6.
- [10] L. P. Deshmukh, T. H. Mujawar, M. S. Kasbe, S. S. Mule, J. Akhtar, and N. N. Maldar, **A LabVIEW based remote monitoring and controlling of wireless sensor node for LPG gas leakage detection**, in *2016 International Symposium on Electronics and Smart Devices (ISESD)*, 2016, pp. 115–120.





- [11] K. Keshamoni and S. Hemanth, **Smart Gas Level Monitoring, Booking & Gas Leakage Detector over IoT**, in *2017 IEEE 7th International Advance Computing Conference (IACC)*, 2017, pp. 330–332.
- [12] G. V. da Silva Medeiros, M. R. Dos Santos, A. S. B. Lopes, and E. C. Barbalho Neto, **Smartgas: a smart platform for cooking gas monitoring**, in *2017 IEEE First Summer School on Smart Cities (S3C)*, 2017, pp. 97–102.
- [13] Z. Aslam, W. Khalid, T. Ahmed, and D. Marghoob, **Automated control system for indoor air quality management**, in *2017 International Conference on Energy Conservation and Efficiency (ICECE)*, 2017, pp. 85–88.
- [14] S. Unnikrishnan, M. Razil, J. Benny, S. Varghese, and C. V. Hari, **LPG monitoring and leakage detection system**, in *2017 International Conference on Wireless Communications, Signal Processing and Networking (WiSPNET)*, 2017, vol. 2018-Janua, pp. 1990–1993.
- [15] B. Artono, T. Lestariningsih, R. G. P. Yudha, and A. A. Bachri, **Motorcycle Security System using SMS Warning and GPS Tracking**, *J. Robot. Control*, vol. 1, no. 5, pp. 150–155, 2020.
- [16] Astuti, Nuraeni Puji, R. Ritzkal, A. H. Hendrawan, and B. A. Prakosa, **Vehicle Security System using Short Message Service (SMS) as a Danger Warning in Motorcycle Vehicles**, *J. Robot. Control*, vol. 1, no. 6, pp. 224–228, 2020.
- [17] B. A. Saputra, E. P. Hidayat, and A. Z. Arfianto, **Internet of Things-Based Steam Pump Motor Protection Due to Voltage Unbalance**, *J. Robot. Control*, vol. 1, no. 2, pp. 64–69, 2020.
- [18] J. Juhariansyah, R. Ritzkal, and A. H. Hendrawan, **Design Of An Automatic Bell Warning System For Prayer Times In A Net Centric Computing Lab**, *J. Robot. Control*, vol. 1, no. 3, pp. 92–95, 2020.
- [19] W. Kartika, I. Santoso, and K. Supriyadi, **Simple Wireless Nurse Call on Distance Measurement**, *J. Robot. Control*, vol. 2, no. 3, pp. 145–147, 2021.
- [20] A. Latif, A. Z. Arfianto, J. E. Poetro, T. N. Phong, and E. T. Helmy, **Temperature Monitoring System for Baby Incubator Based on Visual Basic**, *J. Robot. Control*, vol. 2, no. 1, pp. 47–50, 2021.
- [21] A. Beltran Jr, K. J. Dizon, K. Nones, R. L. Salanguit, J. Bhie Santos, and J. Rei Santos, **Arduino-based Disaster Management System**, *J. Robot. Control*, vol. 2, no. 1, pp. 24–28, 2021.
- [22] A. Hassan *et al.*, **A Wirelessly Controlled Robot-based Smart Irrigation System by Exploiting Arduino**, *J. Robot. Control*, vol. 2, no. 1, pp. 29–34, 2021.
- [23] T. Kalaiselvi, K. Selvasundar, and M. K. Kumaresan, **Maximizing Light Cycle Oil (Lco) production in fluid catalytic cracker**, *Proc. - 2017 IEEE Int. Conf. Technol. Innov. Commun. Control Autom. TICCA 2017*, vol. 2018-Janua, pp. 44–48, 5093.
- [24] J. Prabakaran, A. Swamy, A. Sharma, N. Bharath Kumar, P. R. Mundra, and K. J. Mohammed, **Wireless home automation and security system using MQTT protocol**, *RTEICT 2017 - 2nd IEEE Int. Conf. Recent Trends Electron. Inf. Commun. Technol. Proc.*, vol. 2018-Janua, pp. 2043–2045, 5093.
- [25] R. Muzawi, R. Desmawati, and U. Rio, **Prototype Sistem Pendeteksi Jenis Kayu Menggunakan Sensor MQ-6**, *INOVTEK Polbeng - Seri Inform.*, vol. 4, no. 1, p. 1, 2019.
- [26] Y. Irawan, **Moving Load Robot Using Wifi Network and Android Based**, *J.*





- Robot. Control*, vol. 2, no. 3, pp. 217–220, 2021.
- [27] B. S. Sarjerao and A. Prakasarao, “**A Low Cost Smart Pollution Measurement System Using REST API and ESP32**, in *2018 3rd International Conference for Convergence in Technology (I2CT)*, 5192, pp. 1–5.
- [28] M. S. Islam, **An Intelligent System on Environment Quality Remote Monitoring and Cloud Data Logging Using Internet of Things (IoT)**, in *2018 International Conference on Computer, Communication, Chemical, Material and Electronic Engineering (IC4ME2)*, 5192, pp. 1–4.
- [29] R. Kurzekar, H. Arora, and R. Shrestha, **Embedded Hardware Prototype for Gas Detection and Monitoring System in Android Mobile Platform**, in *2017 IEEE International Symposium on Nanoelectronic and Information Systems (iNIS)*, 5093, vol. 2018-Febru, pp. 6–10.
- [30] I. Prasajo, A. Maselena, O. Tanane, and N. Shahu, **The Design of Earthquake Detector Using Pendulum Swing Based on ATmega328**, *J. Robot. Control*, vol. 2, no. 3, pp. 209–211, 2021.
- [31] R. S. Kharisma and A. Setiyansah, **Fire Early Warning Using Fire Sensors, Microcontroller and SMS Gateway**, *J. Robot. Control*, vol. 2, no. 3, pp. 165–169, 2021.
- [32] R. Wahyuni, A. Rickyta, U. Rahmalisa, and Y. Irawan, **Home Security Alarm Using Wemos D1 And HC-SR501 Sensor Based Telegram Notification**, *J. Robot. Control*, vol. 2, no. 3, pp. 200–204, 2021.
- [33] A. A. Rafiq, W. N. Rohman, and S. D. Riyanto, **Development of a Simple and Low-cost Smartphone Gimbal with MPU-6050 Sensor**, *J. Robot. Control*, vol. 1, no. 4, pp. 136–140, 2020.
- [34] N. F. Apsari, P. Megantoro, M. U. Sattar, A. Maselena, and O. Tanane, **Design of Laboratory Scale Fluid Level Measurement Device Based on Arduino**, *J. Robot. Control*, vol. 1, no. 5, pp. 145–149, 2020.
- [35] S. Z. B. Zaharudin, M. Kazemi, and M. B. Malarvili, **Designing a respiratory CO measurement device for home monitoring of asthma severity**,” in *2014 IEEE Conference on Biomedical Engineering and Sciences (IECBES)*, 2014, no. December, pp. 230–234.
- [36] M. Fukuta, M. Ito, F. Yamaguchi, and H. Nishi, **Construction of HEMS in Japanese cold district for reduction of carbon dioxide emissions**,” in *IECON 2014 - 40th Annual Conference of the IEEE Industrial Electronics Society*, 2014, pp. 5338–5343.
- [37] L. Nachabe, M. Girod-Genet, B. ElHassan, and J. Jammam, **M-health application for neonatal incubator signals monitoring through a CoAP-based multi-agent system**, in *2015 International Conference on Advances in Biomedical Engineering (ICABME)*, 2015, pp. 170–173.





- [38] M. P. Joshi and D. C. Mehetre, **IoT Based Smart Cradle System with an Android App for Baby Monitoring**, in *2017 International Conference on Computing, Communication, Control and Automation (ICCUBEA)*, 2017, pp. 1–4.
- [39] S. Pawar, V. Kithani, S. Ahuja, and S. Sahu, **Smart Home Security Using IoT and Face Recognition**, in *2018 Fourth International Conference on Computing Communication Control and Automation (ICCUBEA)*, 2018, pp. 1–6.
- [40] N. H. Wijaya, M. Ibrahim, N. Shahu, and M. U. Sattar, “**Arduino-based Digital Advanced Audiometer**,” *J. Robot. Control*, vol. 2, no. 2, pp. 83–87, 2021.
- [41] D. Murali, D. R. Rao, S. R. Rao, and M. Ananda, **Pulse Oximetry and IOT based Cardiac Monitoring Integrated Alert System**, in *2018 International Conference on Advances in Computing, Communications and Informatics (ICACCI)*, 2018, pp. 2237–2243.

